

## ▶ Montaj Şekli

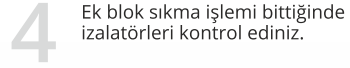

EK BLOK SIKMA DEĞERİ:  
60 lbft (80 Nm)

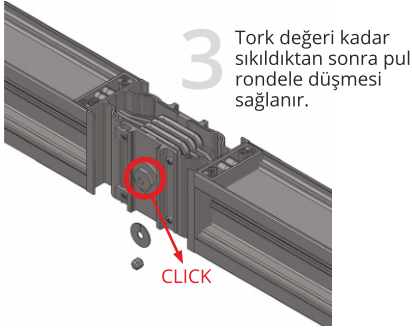
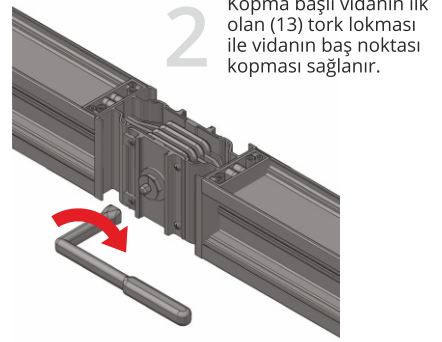
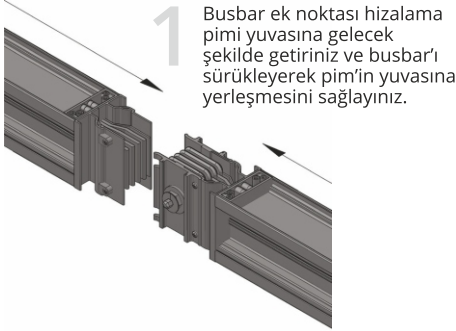
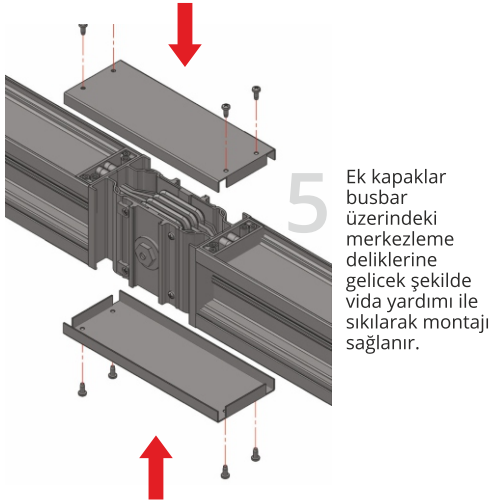

▶ Özel ölçüdeki modüller için lütfen firmamızı arayınız.

## ► Installation Instructions

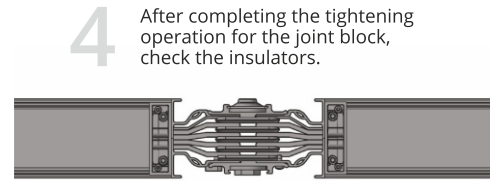
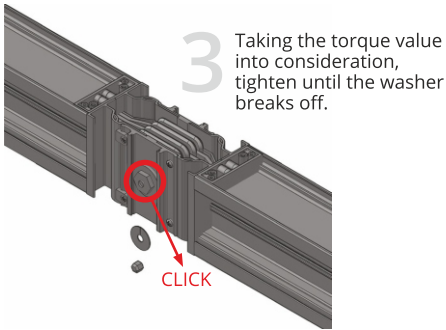
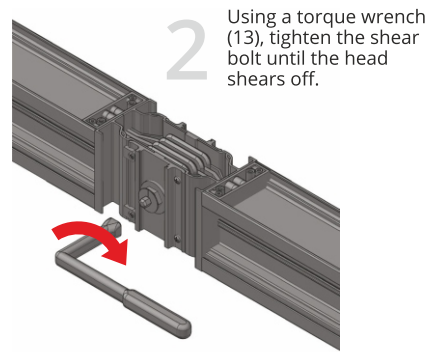
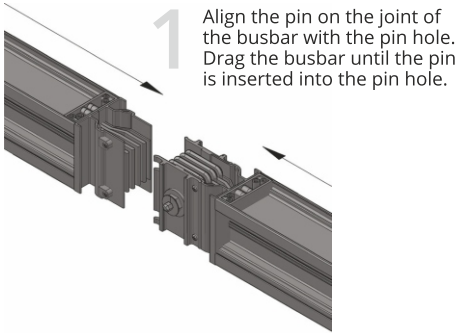

JOINT BLOCK TORQUE VALUE:  
60 lbft (80 Nm)

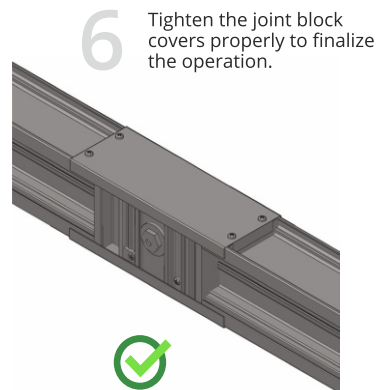
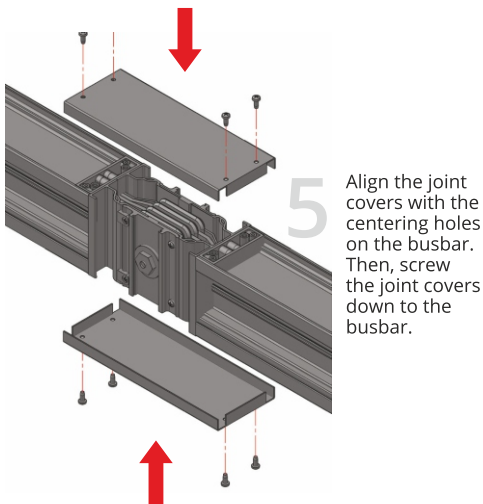

► Please contact us for custom-length modules.